

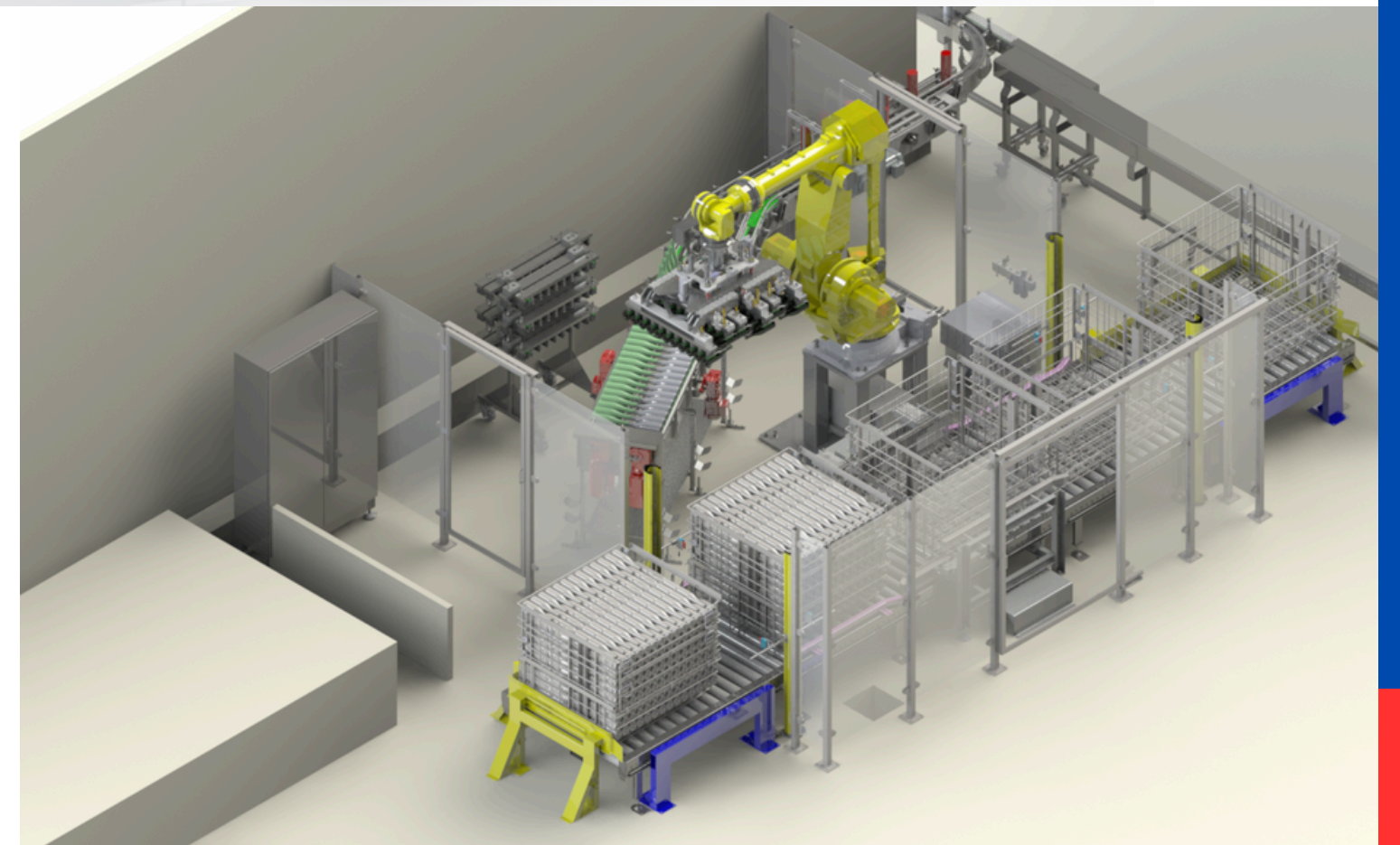

**DESIGN OF EQUIPMENT  
FOR BOTTLING, ROBOTICS  
AND SPECIAL MACHINES  
FROM 500 TO 20 000  
BOTTLES/HOUR**

---

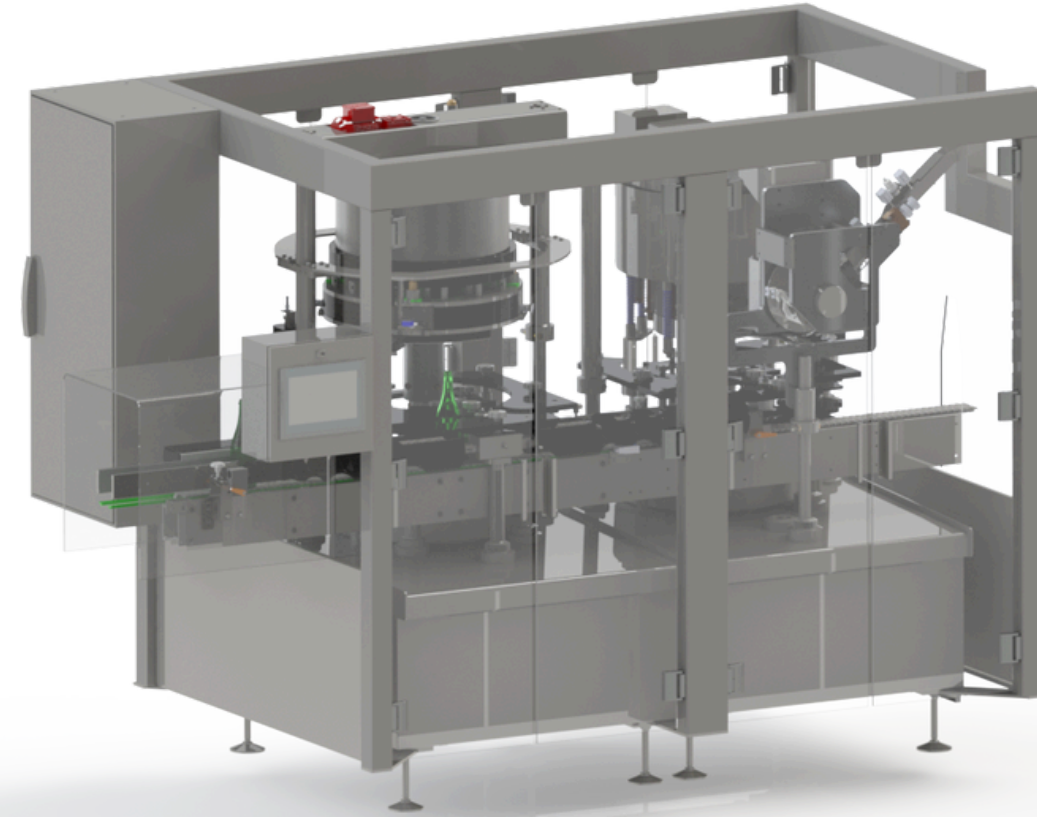

## 01. SPARKLING WINE

### SPARKLING WINE

#### > Filling

Automatic Filling line 3000 b/h

Automatic Filling line 5000 b/h

#### > Disgorging

Semi-automatic Disgorging line 500 b/h

Semi-automatic Disgorging line 700 b/h

Automatic Disgorging line 700 b/h

Automatic Disgorging line 700 b/h

Automatic Disgorging line 700 b/h

Automatic Disgorging line 700 b/h

Automatic Disgorging line 700 b/h

# 01 SPARKLING WINE

FILLING

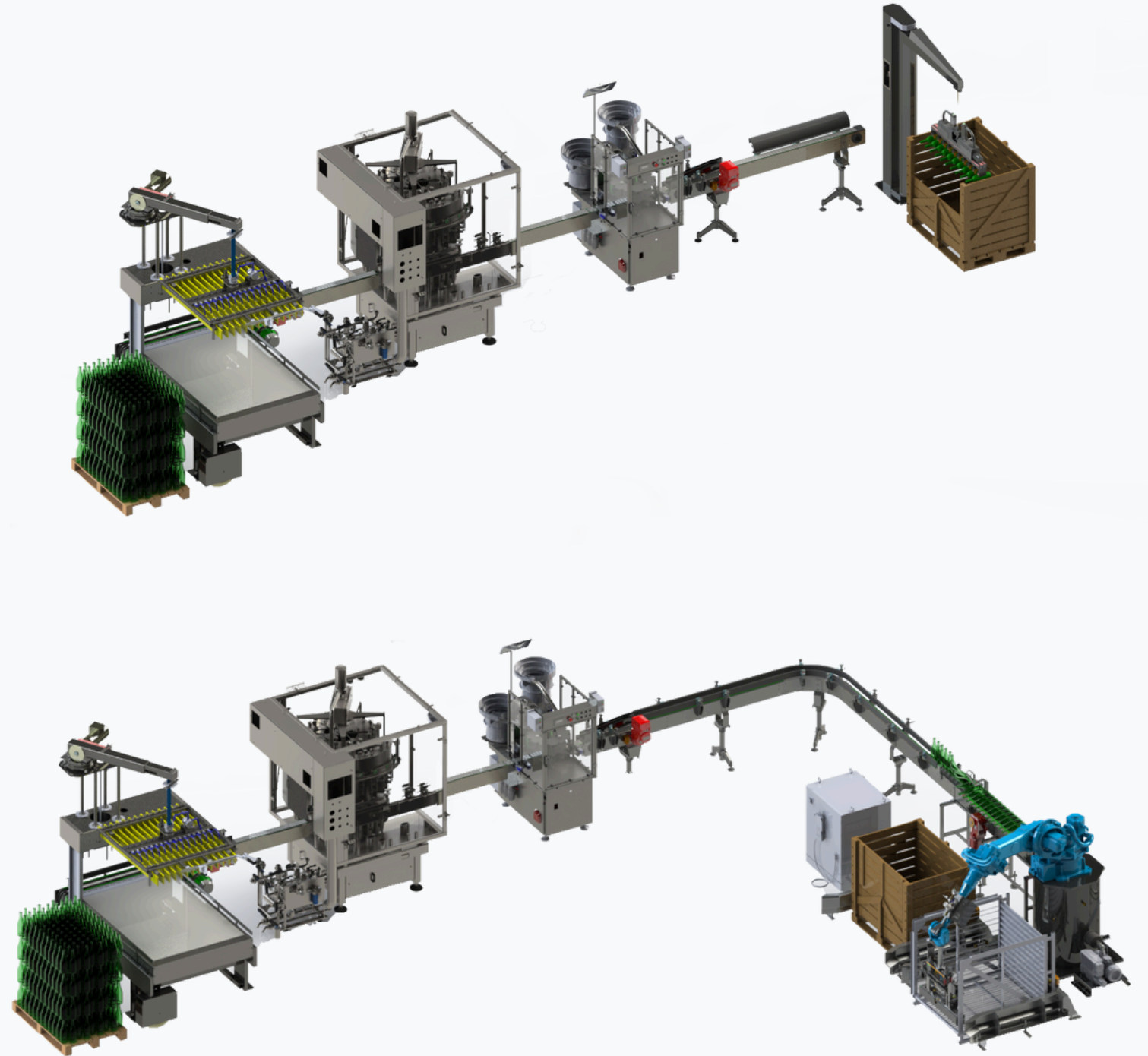

# FILLING

SPARKLING WINE

AUTOMATIC FILLING LINE 3000 b/h

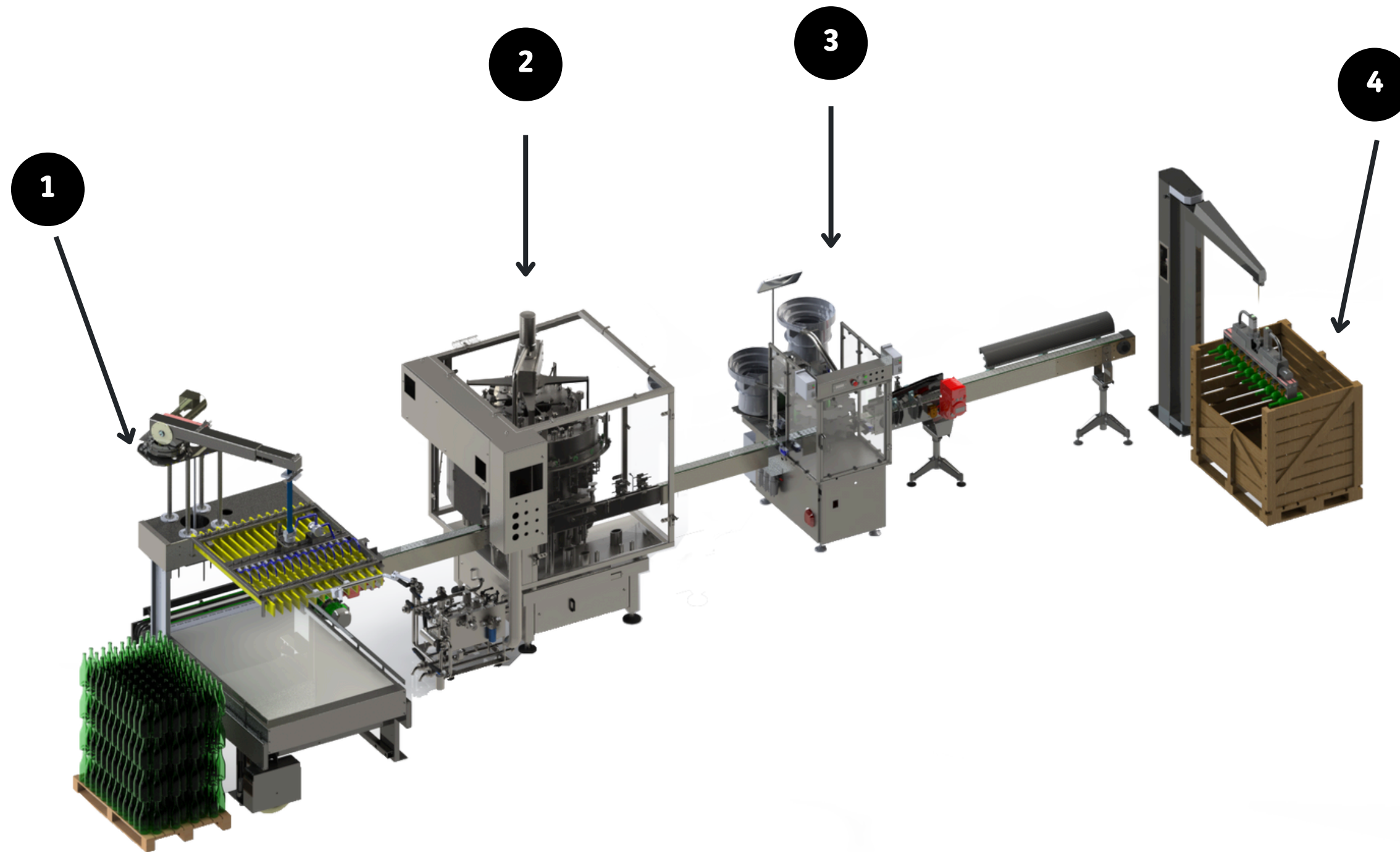

- 1 Semi-automatic depalletiser for new glass
- 2 Automatic filling machine
- 3 Automatic biduling capsuling machine
- 4 Semi-automatic emboxing

# FILLING

## SPARKLING WINE

### AUTOMATIC FILLING LINE 3000 b/h

1

#### **Semi-automatic depalletiser for new glass DEPAL SA**

Supply voltage : 400 volts tri

Power : 4 Kw

Working height : 1000 mm +/- 50mm

Dimensions (L x D x H) : 2660 x 2740 x 2800 mm

Air consumption : - m3/h

Production rate : 10 000 b/h

Weight : -kg



2

#### **Automatic filling machine SR 5000**

Supply voltage : 400 volts tri

Power : 1 Kw

Working height : 1000 mm +/- 50mm

Dimensions (L x D x H) : 1320 x 1650 x 1950 mm

Air consumption : - m3/h

Production rate : 5 000 b/h

Weight : 1250 kg



3

#### **Automatic biduling - Capsuling machine GBCM**

Supply voltage : 400 volts tri

Power : 0,55 Kw

Working height : 950 mm +/- 50 mm

Dimensions (L x D x H) : 1650 x 950 x 1650 mm

Air consumption : 5 m3/h to 6 bars

Production rate : 4500 - 5000 b/h

Weight : 500 kg



4

#### **Semi-automatic emboxing MICROMUTA ( bottles in 1 line)**

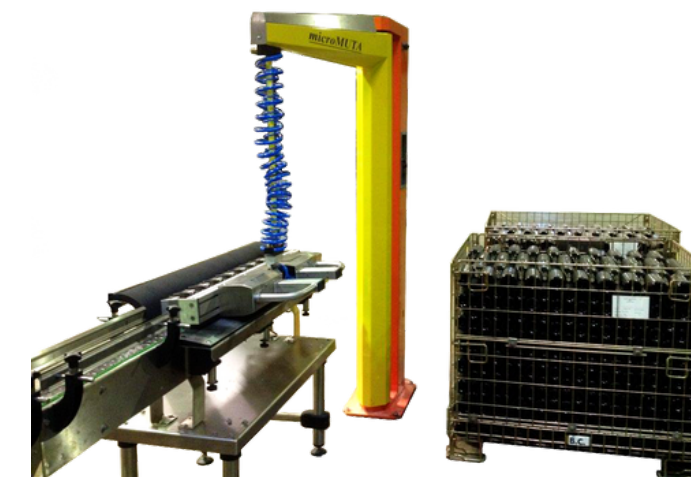

# FILLING

SPARKLING WINE

AUTOMATIC FILLING LINE 5000 b/h

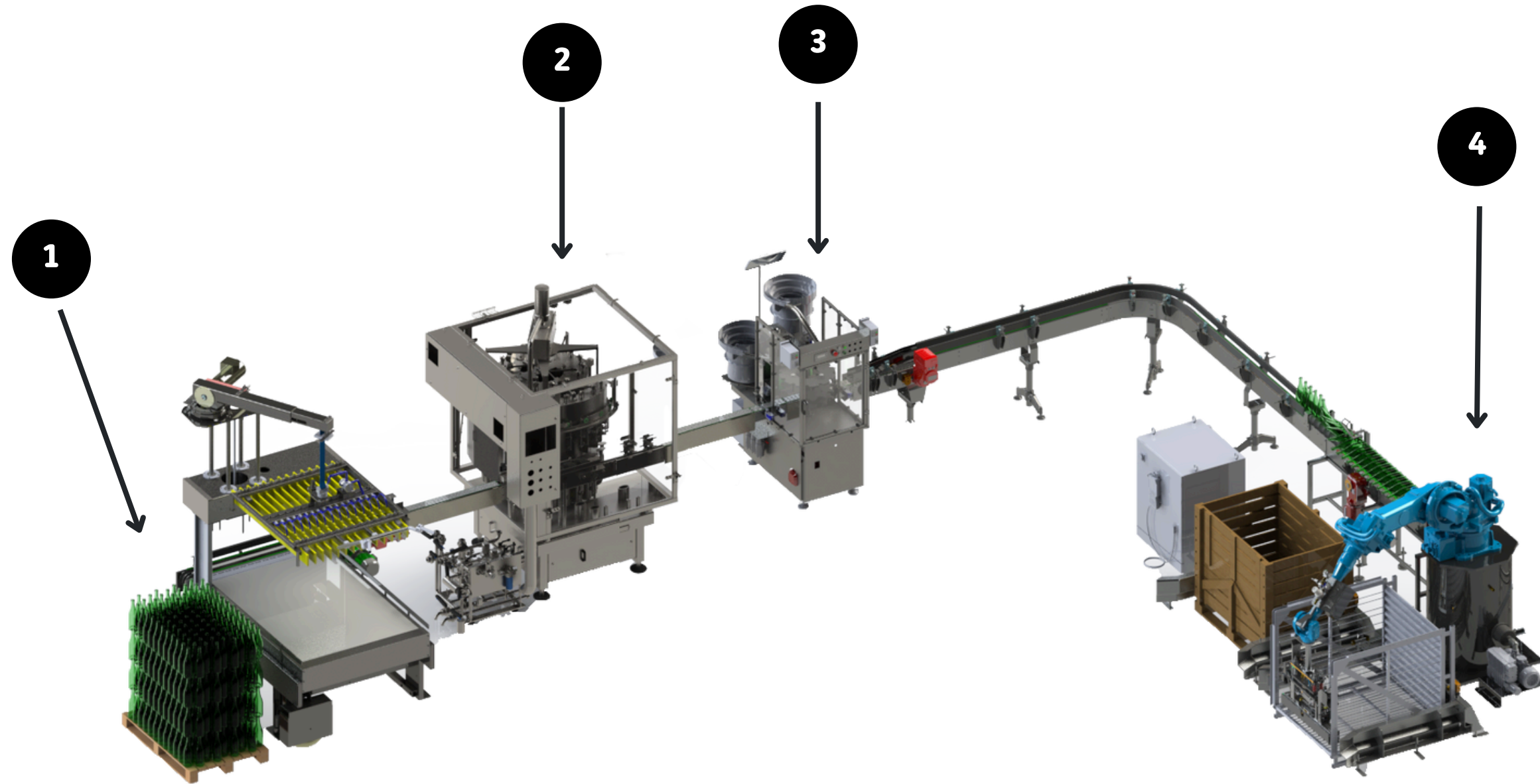

- 1 Semi-automatic depalletiser for new glass
- 2 Automatic filling machine
- 3 Automatic biduling capsuling machine
- 4 Automatic emboxing

# FILLING

## SPARKLING WINE

### AUTOMATIC FILLING LINE 3000 b/h

1

#### **Semi-automatic depalletiser for new glass DEPAL SA**

Supply voltage : 400 volts tri

Power : 4 Kw

Working height : 1000 mm +/- 50mm

Dimensions (L x D x H) : 2660 x 2740 x 2800 mm

Air consumption : - m3/h

Production rate : 10 000 b/h

Weight :- kg



2

#### **Automatic filling machine SR 5000**

Supply voltage : 400 volts tri

Power : 1 Kw

Working height : 1000 mm +/- 50mm

Dimensions (L x D x H) : 1320 x 1650 x 1950 mm

Air consumption : - m3/h

Production rate : 5 000 b/h

Weight : 1250 kg



3

#### **Automatic biduling - Capsuling machine GBCM**

Supply voltage : 400 volts tri

Power : 0,55 Kw

Working height : 950 mm +/- 50 mm

Dimensions (L x D x H) : 1650 x 950 x 1650 mm

Air consumption : 5 m3/h to 6 bars

Production rate : 4500 - 5000 b/h

Weight : 500 kg



4

#### **Automatic emboxing Emboxing robot**



# 01 SPARKLING WINE

**DISGORGING**



# DISGORGING

SPARKLING WINE

SEMI AUTOMATIC DISGORGING LINE 500 b/h

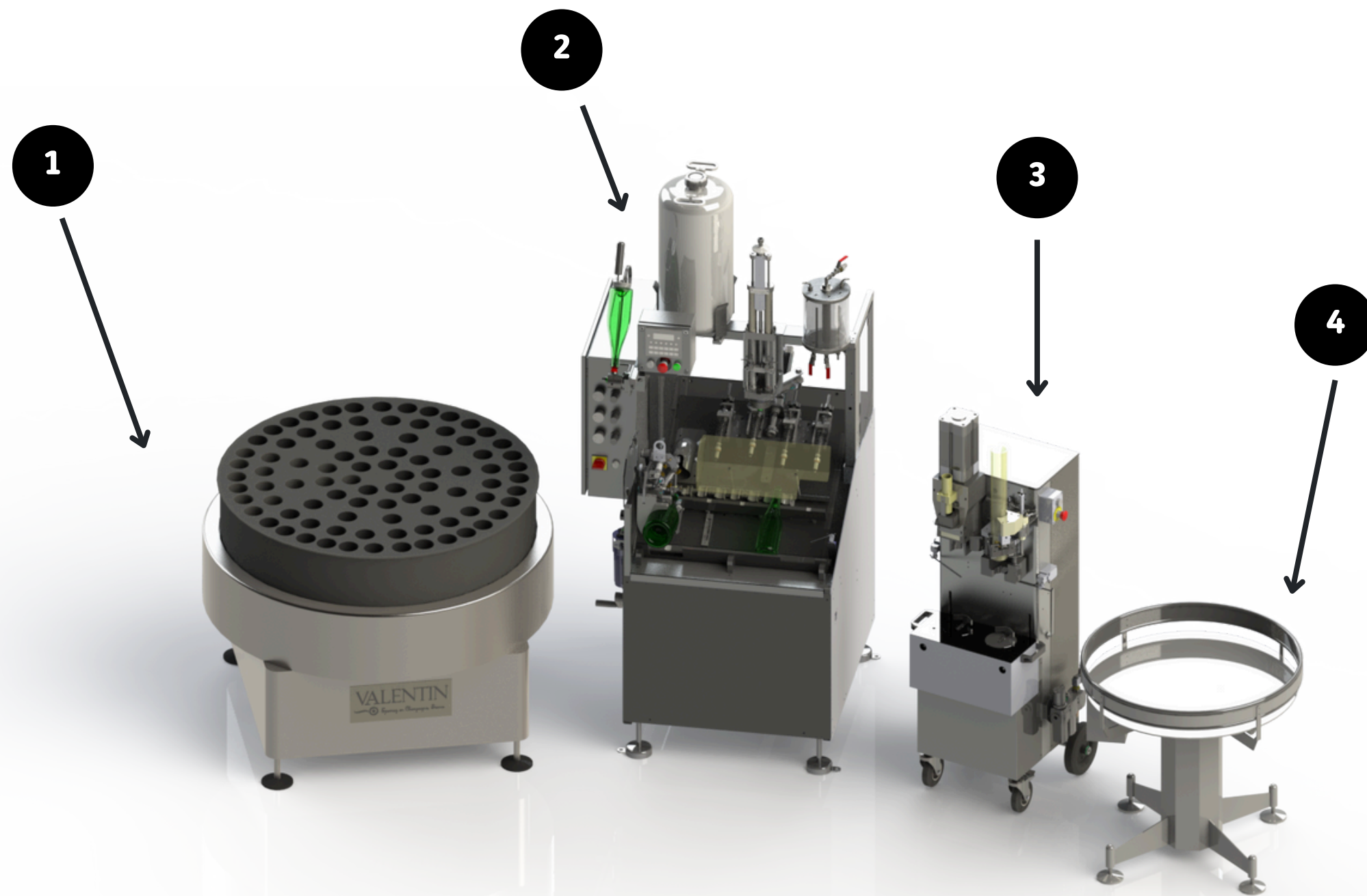

- 1 Neck freezer
- 2 Manual disgorging and dosing machine
- 3 Semi-automatic corking wiring machine
- 4 Reception table

# DISGORGING

## SPARKLING WINE

### SEMI AUTOMATIC DISGORGING LINE 500 b/h

1

#### Neck freezer

Supply voltage : 400 volts tri

Power : 1,4 Kw

Working height : 930 mm

Dimensions (L x D x H) : 1120 x 1120 x 930 mm

Production rate : 500-650 b/h

Weight : 300kg



2

#### Manual disgorging and dosing machine

##### DD 700 M - ELECTRONIC DOSAGE

Supply voltage : 400 volts tri

Power : 1 Kw

Working height : 1000 mm +/- 50mm

Dimensions (L x D x H) : 900 x 1000 x 1900 mm

Air consumption : 10 m3/h to 6 bars

Production rate : 700 b/h

Weight : 250 kg

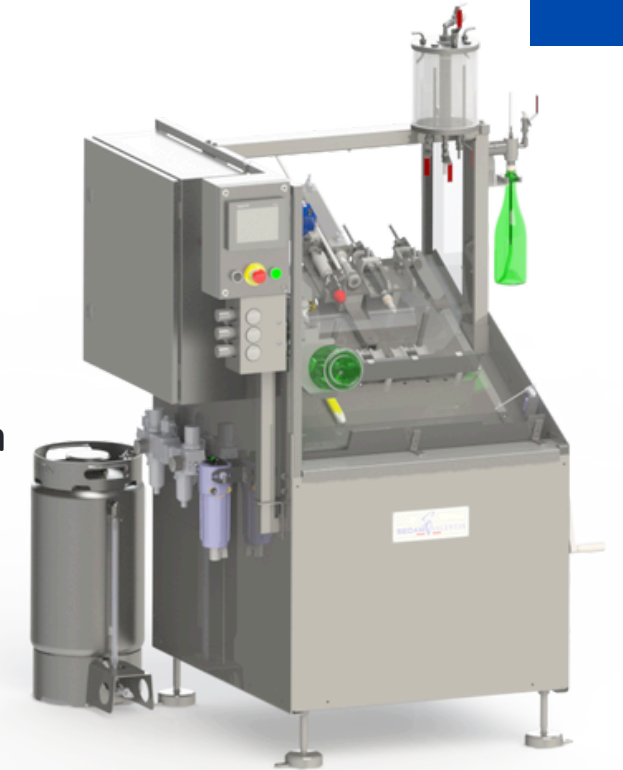

3

#### Semi-Automatic corking wiring machine

##### ECOVAL 20

Supply voltage : 230 volts mono

Power : 0,15 Kw

Working height : 730 mm

Dimensions (L x D x H) : 602 x 580 x 1620 mm

Air consumption : 20 m3/h to 6 bars

Production rate : 500 b/h

Weight : 195 kg



4

#### Reception table

##### TMD 800 - 1000



# DISGORGING

SPARKLING WINE

SEMI AUTOMATIC DISGORGING LINE 700 b/h

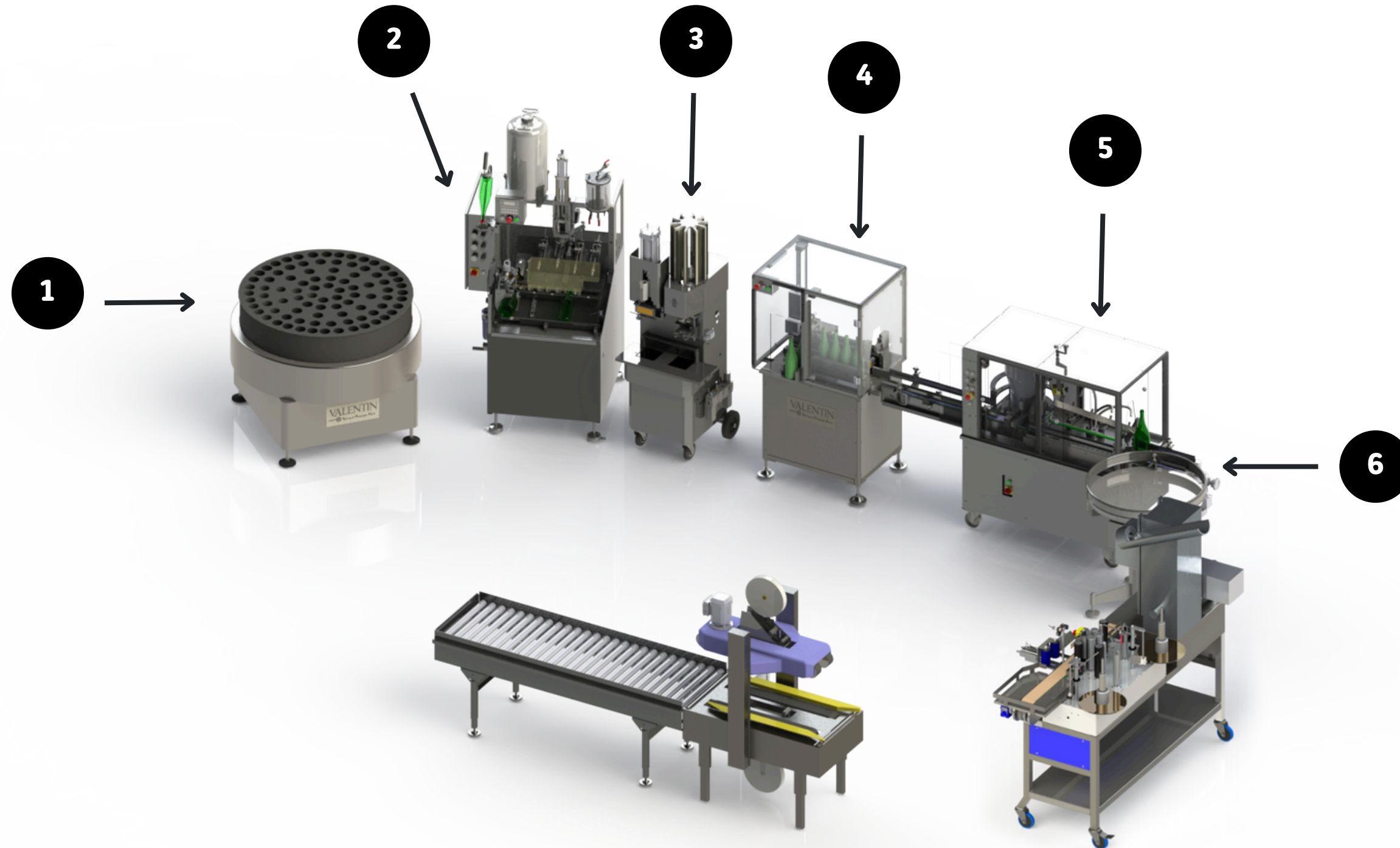

- 1** Neck freezer
- 2** Manual disgorging and dosing machine
- 3** Semi-automatic corking wiring machine
- 4** Mixing machine
- 5** Washing drying machine
- 6** Reception table

# DISGORGING

## SPARKLING WINE

### SEMI AUTOMATIC DISGORGING LINE 700 b/h

1

#### Neck freezer

Supply voltage : 400 volts tri

Power : 2,8 Kw

Working height : 950 mm

Dimensions (L x D x H) : 1300 x 1300 x 930 mm

Production rate : 700-950 b/h

Weight : 385 kg



2

#### Manual disgorging and dosing machine

##### DD 700 M - ELECTRONIC DOSAGE

Supply voltage : 400 volts tri

Power : 0,20 Kw

Working height : 900 mm +/- 50mm

Dimensions (L x D x H) : 900 x 1000 x 1900 mm

Air consumption : 10 m3/h to 6 bars

Production rate : 700 b/h

Weight : 250 kg



Cork  
reserve



3

#### Semi-Automatic corking wiring machine

##### FRANVAL 80

Supply voltage : 230 volts mono

Power : 1,5 Kw

Working height : 730 mm

Dimensions (L x D x H) : 685 x 660 x 1790 mm

Air consumption : 25 m3/h to 6 bars

Production rate : 800 b/h

Weight : 285 kg

4

#### Mixing machine 4 bottles

##### AG4B

Supply voltage : 230 volts mono

Power : 0,15 Kw

Working height : 900 mm +/- 50 mm

Dimensions (L x D x H) : 950 x 1150 x 1400 mm

Air consumption : 18 m3/h to 6 bars

Production rate : 1200 b/h

Weight: 230 kg



# DISGORGING

## SPARKLING WINE

### SEMI AUTOMATIC DISGORGING LINE 700 b/h

5

#### Washing drying machine

Supply voltage : 400 volts tri

Power : 7,00 Kw

Working height : 875 mm

Dimensions (L x D x H) : 2415 x 690 x 1710 mm

Water consumption : 100 l/h

Production rate : 1000 b/h

Weight : 380 kg



6

#### Reception table

TMD 800 - 1000



# DISGORGING

SPARKLING WINE

AUTOMATIC DISGORGING LINE 700 b/h

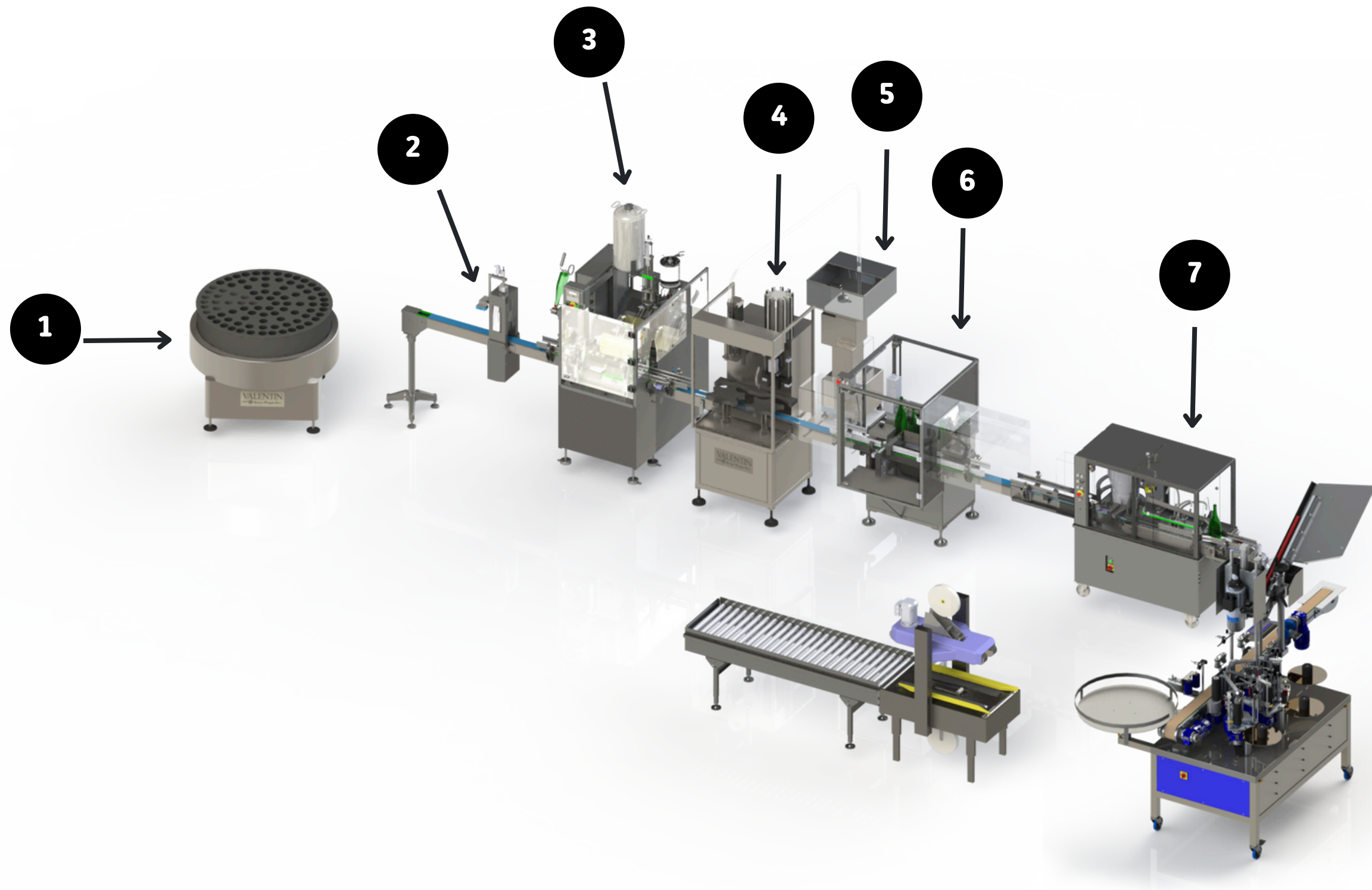

- 1 Neck freezer
- 2 Neck rinsing tunnel
- 3 Automatic disgorging dosing machine
- 4 Automatic corking and wiring machine
- 5 Cork distributor and orientator
- 6 Mixing machine
- 7 Washing drying machine

# DISGORGING

## SPARKLING WINE

### AUTOMATIC DISGORGING LINE 700 b/h

1

#### Neck freezer

Supply voltage : 400 volts tri

Power : 2,8 Kw

Working height : 950 mm

Dimensions (L x D x H) : 1300 x 1300 x 930 mm

Production rate : 700 b/h

Weight : 275 kg



2

#### Neck rinsing tunnel RC PE

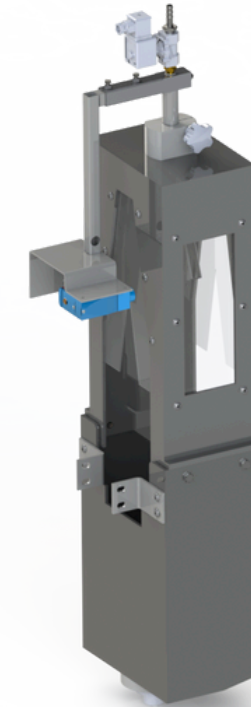

3

#### Manual disgorging and dosing machine DD 700 - ELECTRONIC DOSAGE

Supply voltage. : 400 volts tri

Power : 0,20 Kw

Working height : 900 mm +/- 50 mm

Dimensions (L x D x H) : 1350 x 1350 x 1900 mm

Air consumption : 10 m3/h to 6 bars

Production rate : 700 b/h

Weight : 275 kg

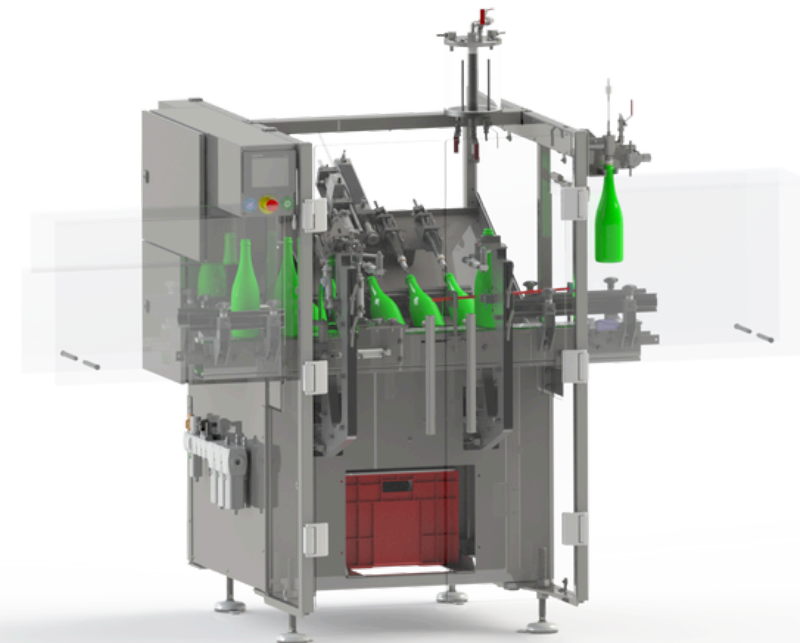

4

#### Automatic corking and wiring machine FRANVAL 1000

Supply voltage : 400 volts tri

Power : 0,40 Kw

Working height : 900 mm +/- 50 mm

Dimensions (L x D x H) : 1050 x 900 x 2000 mm

Air consumption. : 25 m3/h to 6 bars

Production rate : 1000 b/h



# DISGORGING

## SPARKLING WINE

### AUTOMATIC DISGORGING LINE 700 b/h

5

#### **Cork distributor and orientator DOB 3000**

Supply voltage : 400 volts tri

Power : 0,50 Kw

Dimensions (L x D x H) . 600 x 700 x 1900 mm

Air consumption. . 10 m3/h to 6 bars

Production rate : 1500 to 3000 b/h

Weight : 90 kg

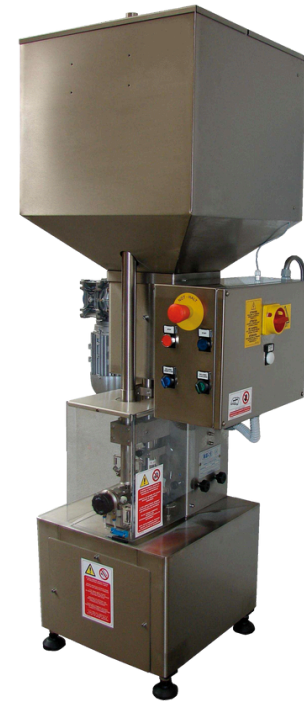

6

#### **Mixing machine 4 bottles**

Supply voltage : 230 volts mono

Power. : 0,15 Kw

Working height. : 900 mm +/- 50 mm

Dimensions (L x D x H) : 950 x 1150 x 1400 mm

Air consumption : 18 m3/h to 6 bars

Production rate : 1200 b/h

Weight : 230 kg



7

#### **Washing drying machine**

Supply voltage : 400 volts tri

Power : 7,00 Kw

Working height : 875 mm

Dimensions (L x D x H) : 2415 x 690 x 1710 mm

Water consumption : 100 l/h

Production rate : 1000 b/h

Weight : 380 kg





# DISGORGING

SPARKLING WINE

AUTOMATIC DISGORGING LINE 1000 b/h

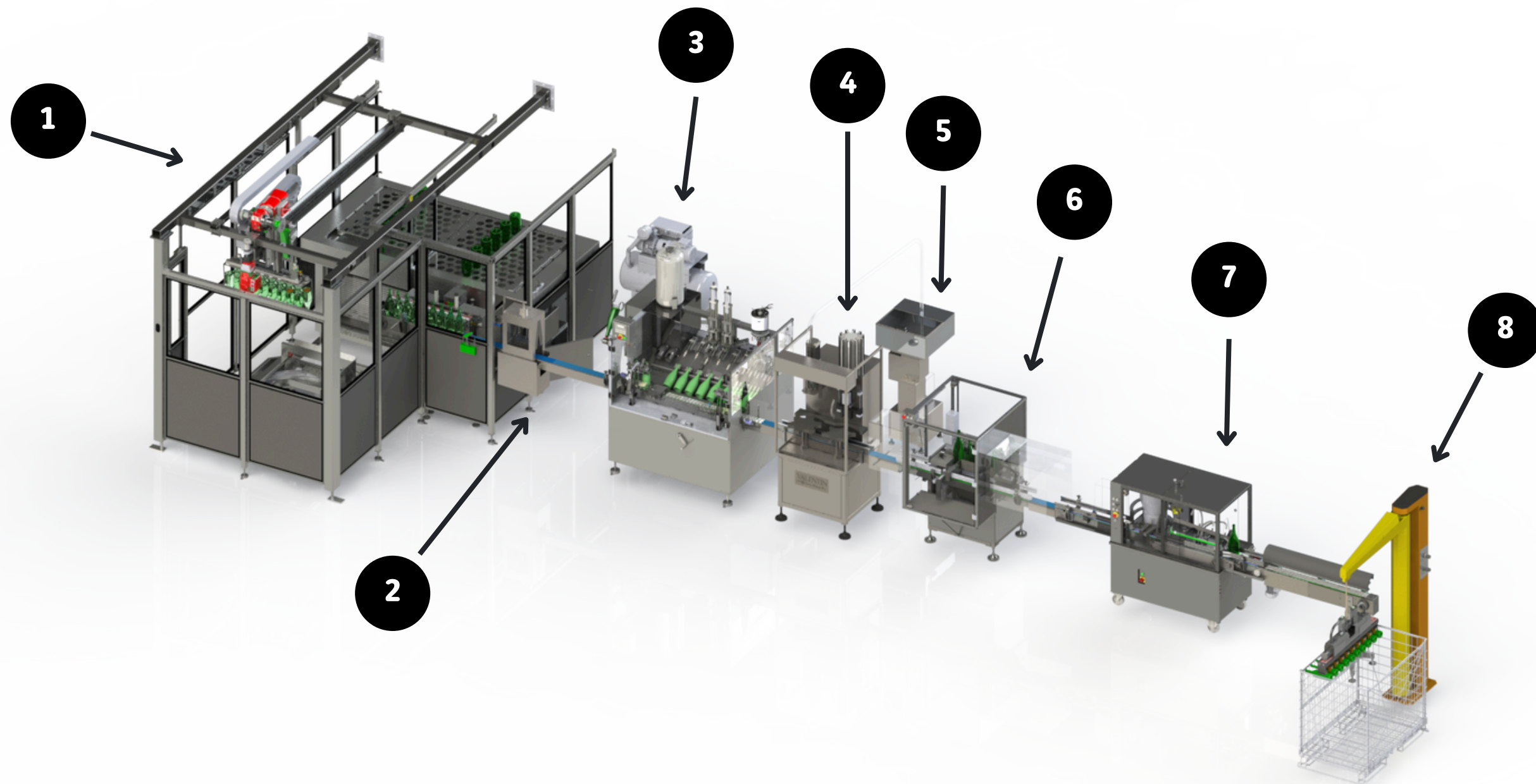

- 1 Neck freezer
- 2 Neck rinsing tunnel
- 3 Automatic disgorging dosing machine
- 4 Automatic corking and wiring machine
- 5 Cork distributor and orientator
- 6 Mixing machine
- 7 Washing drying machine
- 8 Semi-automatic emboxing

# DISGORGING

## SPARKLING WINE

### AUTOMATIC DISGORGING LINE 1000 b/h

1

**Neck freezer  
BGR 1200**

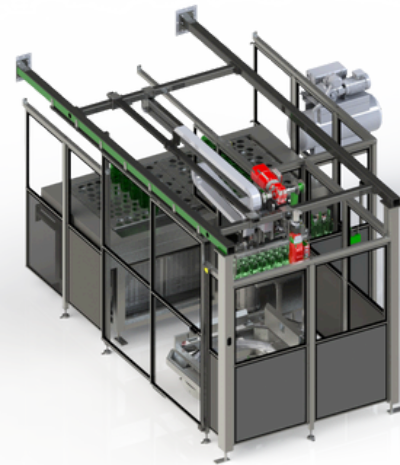

2

**Neck rinsing tunnel  
RC Inox**



3

**Automatic disgorging and dosing machine  
DDA 1000 - ELECTRONIC DOSAGE**

Supply voltage : 400 volts tri  
Power : 0,20 Kw  
Working height : 900 mm +/- 50 mm  
Dimensions (L x D x H) : 1350 x 1350 x 1900 mm  
Air consumption : 10 m3/h to 6 bars  
Production rate : 1000 b/h

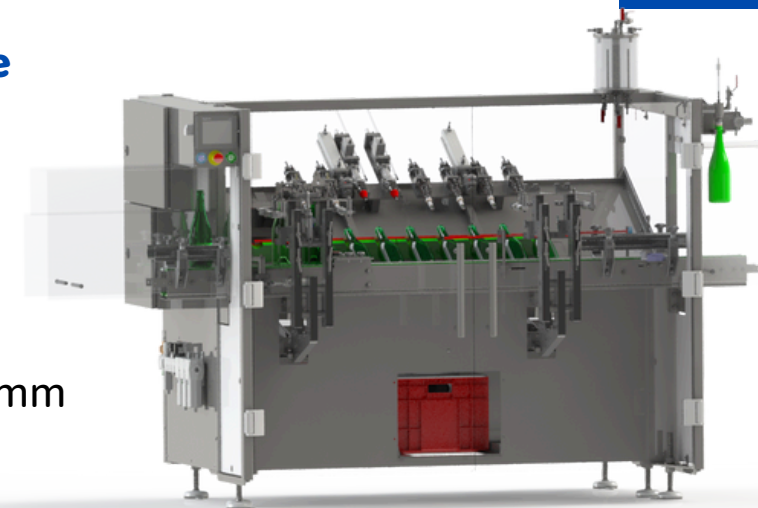

4

**Automatic corking and wiring machine  
FRANVAL 1000**

Supply voltage : 400 volts tri  
Power : 0,40 Kw  
Working height : 900 mm +/- 50 mm  
Dimensions (L x D x H) : 1050 x 900 x 2000 mm  
Air consumption. : 25 m3/h to 6 bars  
Production rate : 1000 b/h  
Weight : 550 kg



5

**Cork distributor and orientator  
DOB 3000**

Supply voltage : 400 volts tri  
Power : 0,50 Kw  
Dimensions (L x D x H) . . 600 x 700 x 1900 mm  
Air consumption. . 10 m3/h to 6 bars  
Production rate : 1500 to 3000 b/h  
Weight : 90 kg



# DISGORGING

## SPARKLING WINE

### AUTOMATIC DISGORGING LINE 1000 b/h

6

#### Mixing machine 4 bottles

Supply voltage : 230 volts mono

Power. : 0,15 Kw

Working height. : 900 mm +/- 50 mm

Dimensions (L x D x H) : 950 x 1150 x 1400 mm

Air consumption : 18 m<sup>3</sup>/h to 6 bars

Production rate : 1200 b/h

Weight : 230 kg



7

#### Washing drying machine

Supply voltage : 400 volts tri

Power : 7,00 Kw

Working height : 875 mm

Dimensions (L x D x H) : 2415 x 690 x 1710 mm

Water consumption : 100 l/h

Production rate : 1000 b/h

Weight : 380 kg



8

#### Semi-Automatic emboxing

MiCROMUTA ( bottles in 1 line)



# DISGORGING

## SPARKLING WINE

### AUTOMATIC DISGORGING LINE 1500 b/h

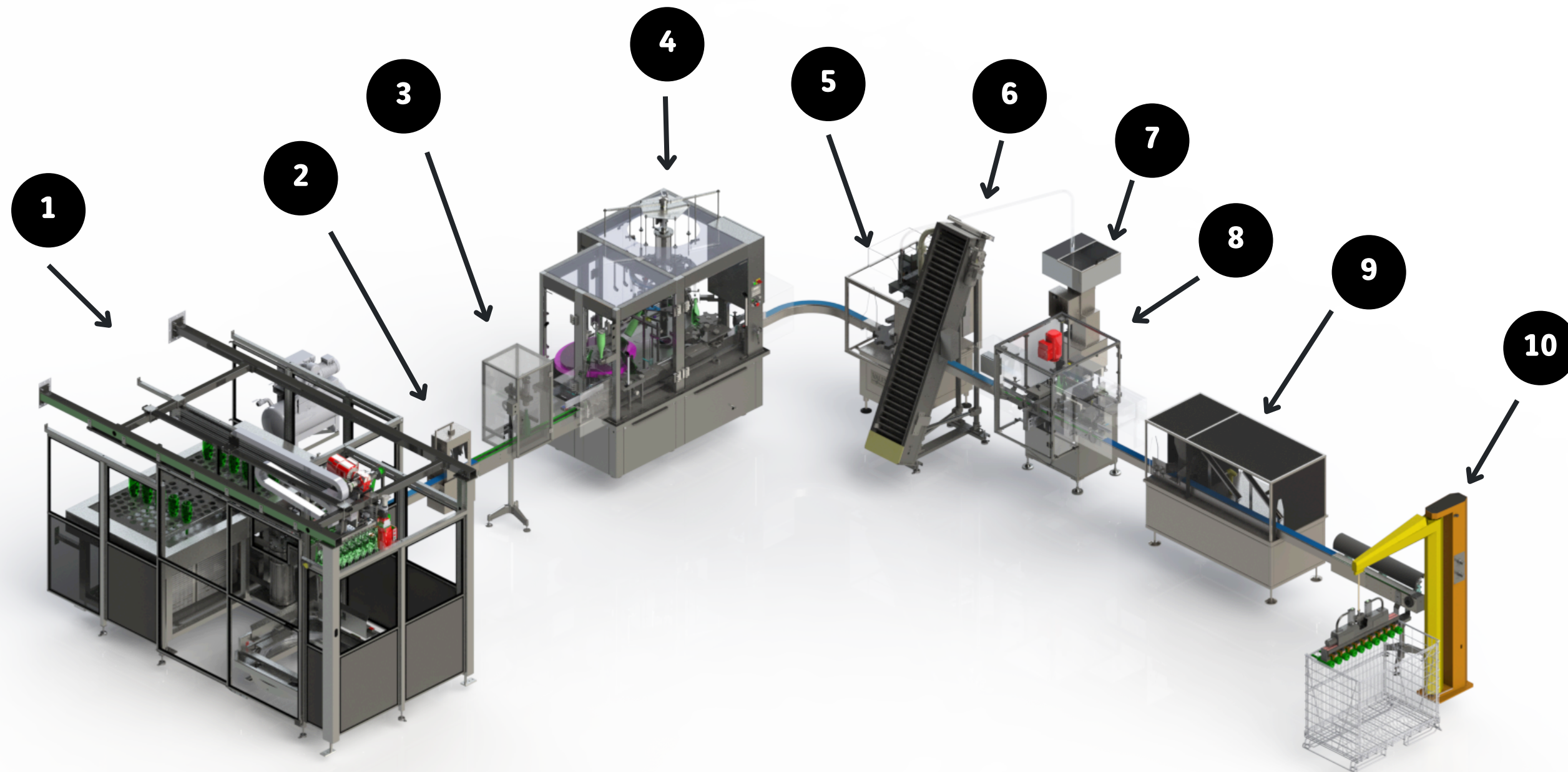

- 1 Neck freezer
- 2 Neck rinsing tunnel
- 3 Beating machine
- 4 Monobloc disgorging rotating dosing
- 5 Automatic corking and wiring machine
- 6 Reserve of wirehoods
- 7 Cork distributor and orientator
- 8 Mixing machine
- 9 Washing drying machine
- 10 Semi-automatic emboxing

# DISGORGING

## SPARKLING WINE

### AUTOMATIC DISGORGING LINE 1500 b/h

1

**Neck freezer  
BGR 1500**

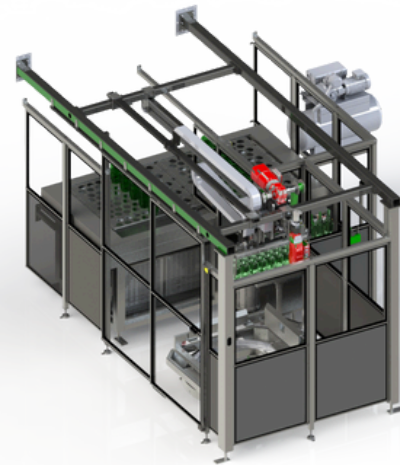

2

**Neck rinsing tunnel  
RC Inox**



3

**Beating machine  
MAF 1**

Working height. . 1000 mm +/- 100 mm  
Dimensions (L x D x H). . 420 x 600 x 1850 mm  
Pressure. . 6 bars  
Air consumption : 5 m<sup>3</sup>/h to 6 bars  
Production rate : 4000 b/h  
Weight : 50 kg



4

**Disgorging and dosage rotating monobloc**



5

**Automatic corking and wiring machine  
Mecaval 12-18**

Supply voltage : 400 volts tri  
Power : 2,20 Kw  
Working height : Mini 900 +/- 50 mm  
Dimensions (L x D x H) : 950 x 1200 x 2040  
Air consumption : 2m<sup>3</sup>/h to 6 bars  
Production rate : 1200 to 1800 b/h  
Weight : 960 kg



# DISGORGING

## SPARKLING WINE

### AUTOMATIC DISGORGING LINE 1500 b/h

6

#### **Reserve of wirehoods RM 2100 U**

Supply voltage : 400 volts tri

Power : 0,30 Kw

Dimensions (L x D x H) : 750 x 500 x 2650 mm

Reserve : 2100 wirehoods

Air consumption. : 2 m<sup>3</sup>/h to 6 bars

Weight : 250 kg



7

#### **Cork distributor and orientator DOB 3000**

Supply voltage : 400 volts tri

Power : 0,50 Kw

Dimensions (L x D x H) . 600 x 700 x 1900 mm

Air consumption. . 10 m<sup>3</sup>/h to 6 bars

Production rate : 1500 to 3000 b/h

Weight : 90 kg



8

#### **Mixing machine**

Supply voltage : 400 volts tri

Power : 1,50 Kw

Working height : 950 mm

Dimensions (L x D x H) : 1500 x 990 x 1575 mm

Air consumption : 10 m<sup>3</sup>/h to 6 bars

Production rate. . 1800 b/h

Weight : 350 kg



# DISGORGING

## SPARKLING WINE

### AUTOMATIC DISGORGING LINE 1500 b/h

9

#### **Washing drying machine**

Supply voltage : 400 volts tri

Power : 11,00 Kw

Working height : 875 mm

Dimensions (L x D x H) : 3015 x 690 x 1710 mm

Water consumption : 100 l/h

Production rate : 2000 b/h

Weight. : 480 kg



10

#### **Semi-automatic emboxing**

**MiCROMUTA ( bottles in 1 line)**



# DISGORGING

## SPARKLING WINE

### AUTOMATIC DISGORGING LINE 2000 b/h

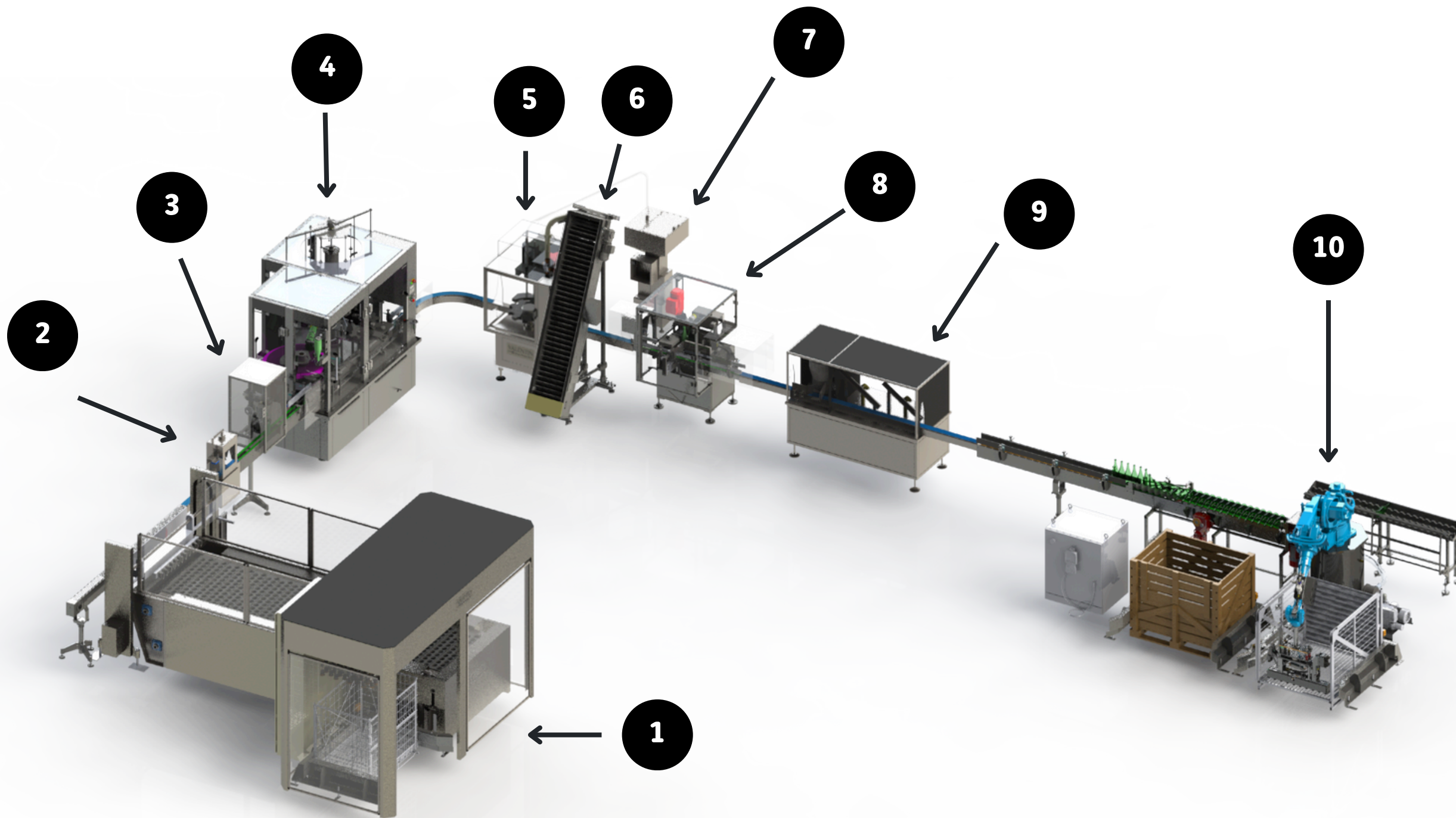

- 1** Neck freezer
- 2** Neck rinsing tunnel
- 3** Beating machine
- 4** Monobloc disgorging rotaty dosing
- 5** Automatic corking and wiring machine
- 6** Reserve of wirehood
- 7** Cork distributor and orientator
- 8** Mixing machine
- 9** Washing drying machine
- 10** Automatic emboxing



# DISGORGING

## SPARKLING WINE

### AUTOMATIC DISGORGING LINE 2000 b/h

1

**Neck freezer  
BGL 2000**

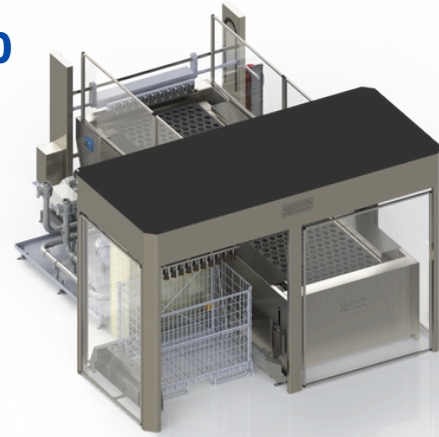

2

**Neck rinsing tunnel  
RC Inox**



3

**Beating machine  
MAF 1**

Working height . . 1000 mm +/- 100 mm  
Dimensions (L x D x H) . . 420 x 600 x 1850 mm  
Pressure . . 6 bars  
Air consumption : 5 m<sup>3</sup>/h to 6 bars  
Production rate : 4000 b/h  
Weight : 50 kg



4

**Disgorging and dosage rotating monobloc**



5

**Automatic corking and wiring machine  
Mecaval 25-30**

Supply voltage : 400 volts tri  
Power : 2,20 Kw  
Working height : Mini 900 +/- 50 mm  
Dimensions (L x D x H) : 950 x 1200 x 2040 mm  
Air consumption : 2m<sup>3</sup>/h to 6 bars  
Production rate : 2500 to 3000 b/h  
Weight : 960 kg



# DISGORGING

## SPARKLING WINE

### AUTOMATIC DISGORGING LINE 2000 b/h

6

#### **Reserve of wirehoods RM 2100 U**

Supply voltage : 400 volts tri

Power : 0,30 Kw

Dimensions (L x D x H) : 750 x 500 x 2650 mm

Reserve : 2100 wirehoods

Air consumption. : 2 m3/h to 6 bars

Weight : 250 kg



7

#### **Cork distributor and orientator DOB 3000**

Supply voltage : 400 volts tri

Power : 0,50 Kw

Dimensions (L x D x H) . 600 x 700 x 1900 mm

Air consumption. . 10 m3/h to 6 bars

Production rate : 1500 to 3000 b/h

Weight : 90 kg



8

#### **Mixing machine**

Supply voltage : 400 volts tri

Power : 1,50 Kw

Working height : 950 mm

Dimensions (L x D x H) : 1500 x 990 x 1575 mm

Air consumption : 10 m3/h to 6 bars

Production rate. . 1800 b/h

Weight : 350 kg



# DISGORGING

## SPARKLING WINE

### AUTOMATIC DISGORGING LINE 2000 b/h

9

#### Washing drying machine

Supply voltage : 400 volts tri

Power : 11,00 Kw

Working height : 875 mm

Dimensions (L x D x H) : 3015 x 690 x 1710 mm

Water consumption : 100 l/h

Production rate : 2000 b/h

Weight. : 480 kg



10

#### Automatic emboxing

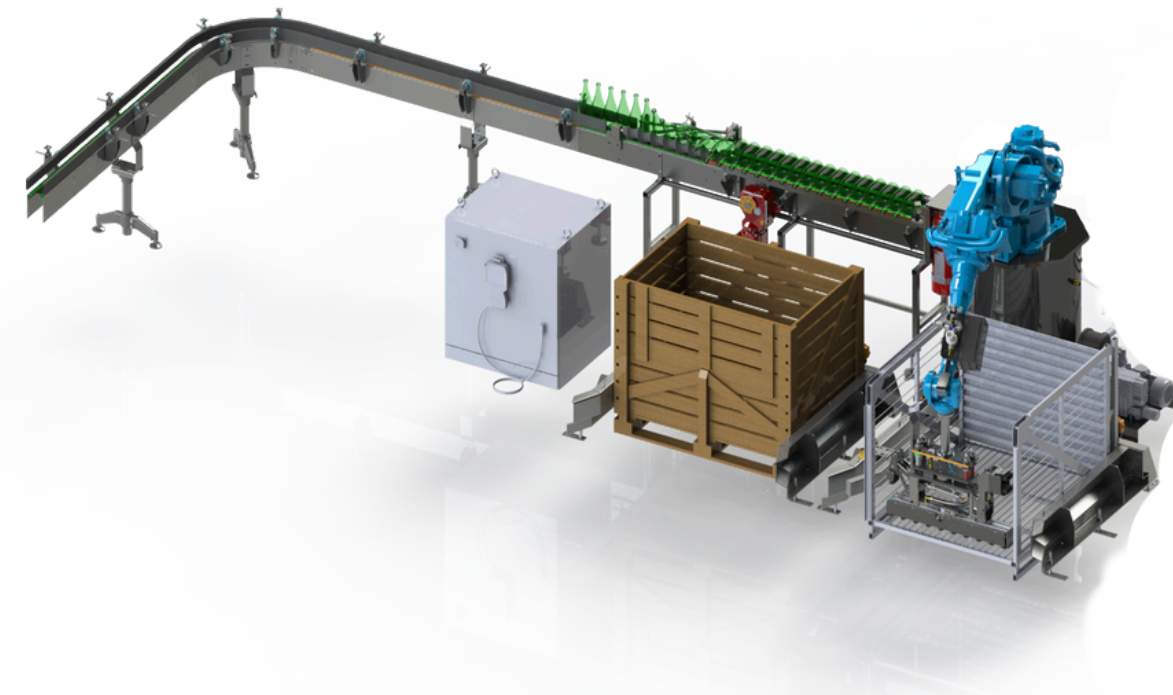

# DISGORGING

SPARKLING WINE

AUTOMATIC DISGORGING LINE 3000 b/h

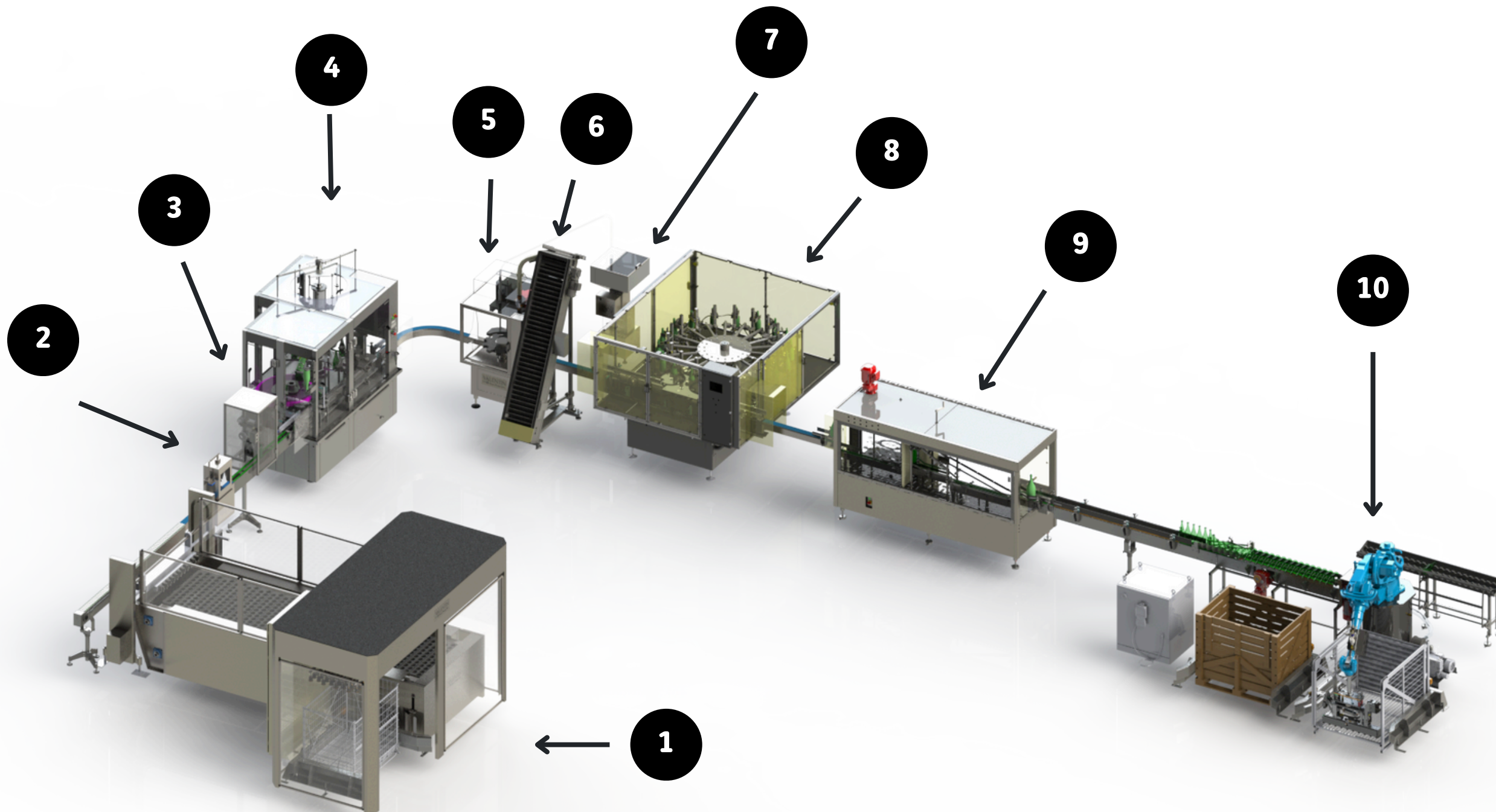

- 1** Neck freezer
- 2** Neck rinsing tunnel
- 3** Beating machine
- 4** Monobloc disgorging rotating dosing
- 5** Automatic corking and wiring machine
- 6** Reserve of wirehood
- 7** Cork distributor and orientator
- 8** Mixing machine
- 9** Washing drying machine
- 10** Automatic emboxing

# DISGORGING

## SPARKLING WINE

### AUTOMATIC DISGORGING LINE 3000 b/h

1

**Neck freezer  
BGL 3000**



2

**Neck rinsing tunnel  
RC Inox**



3

**Beating machine  
MAF 1**

Working height . . 1000 mm +/- 100 mm  
Dimensions (L x D x H) . . 420 x 600 x 1850 mm  
Pressure . . 6 bars  
Air consumption : 5 m<sup>3</sup>/h to 6 bars  
Production rate : 4000 b/h  
Weight : 50 kg



4

**Disgorging and dosage rotating monobloc**



5

**Automatic corking and wiring machine  
Mecaval 30**

Supply voltage : 400 volts tri  
Power : 2,20 Kw  
Working height : Mini 900 +/- 50 mm  
Dimensions (L x D x H) : 950 x 1200 x 2040 mm  
Air consumption : 2m<sup>3</sup>/h to 6 bars  
Production rate : 3000 b/h  
Weight : 960 kg



# DISGORGING

## SPARKLING WINE

### AUTOMATIC DISGORGING LINE 3000 b/h

6

#### **Reserve of wirehoods RM 2100 U**

Supply voltage : 400 volts tri

Power : 0,30 Kw

Dimensions (L x D x H) : 750 x 500 x 2650 mm

Reserve : 2100 wirehoods

Air consumption. : 2 m<sup>3</sup>/h to 6 bars

Weight : 250 kg



7

#### **Cork distributor and orientator DOB 3000**

Supply voltage : 400 volts tri

Power : 0,50 Kw

Dimensions (L x D x H) . 600 x 700 x 1900 mm

Air consumption. . 10 m<sup>3</sup>/h to 6 bars

Production rate : 1500 to 3000 b/h

Weight : 90 kg



8

#### **Mixing machine AGR**

Supply voltage : 400 volts tri

Power : 1,50 Kw

Working height : 950 mm

Dimensions (L x D x H) : 1500 x 990 x 1575 mm

Air consumption : 10 m<sup>3</sup>/h to 6 bars

Production rate. . 1800 b/h

Weight : 350 kg



# DISGORGING

## SPARKLING WINE

### AUTOMATIC DISGORGING LINE 3000 b/h

9

#### Washing drying machine

Supply voltage : 400 volts tri

Power : 18,00 Kw

Working height : 1000 mm

Dimensions (L x D x H) : 2840 x 1105 x 2200 mm

Water consumption : 100 l/h

Production rate : 3000 b/h

Weight. : 580 kg



10

#### Automatic emboxing

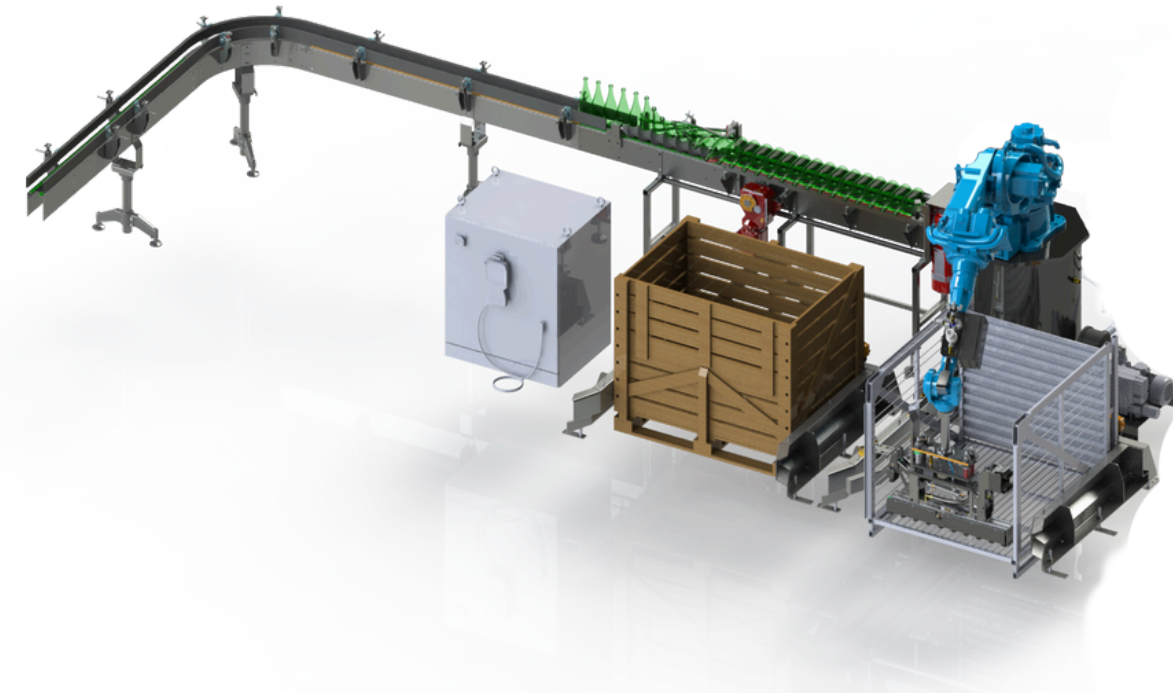

# DISGORGING

## SPARKLING WINE

### AUTOMATIC DISGORGING LINE 4000 b/h

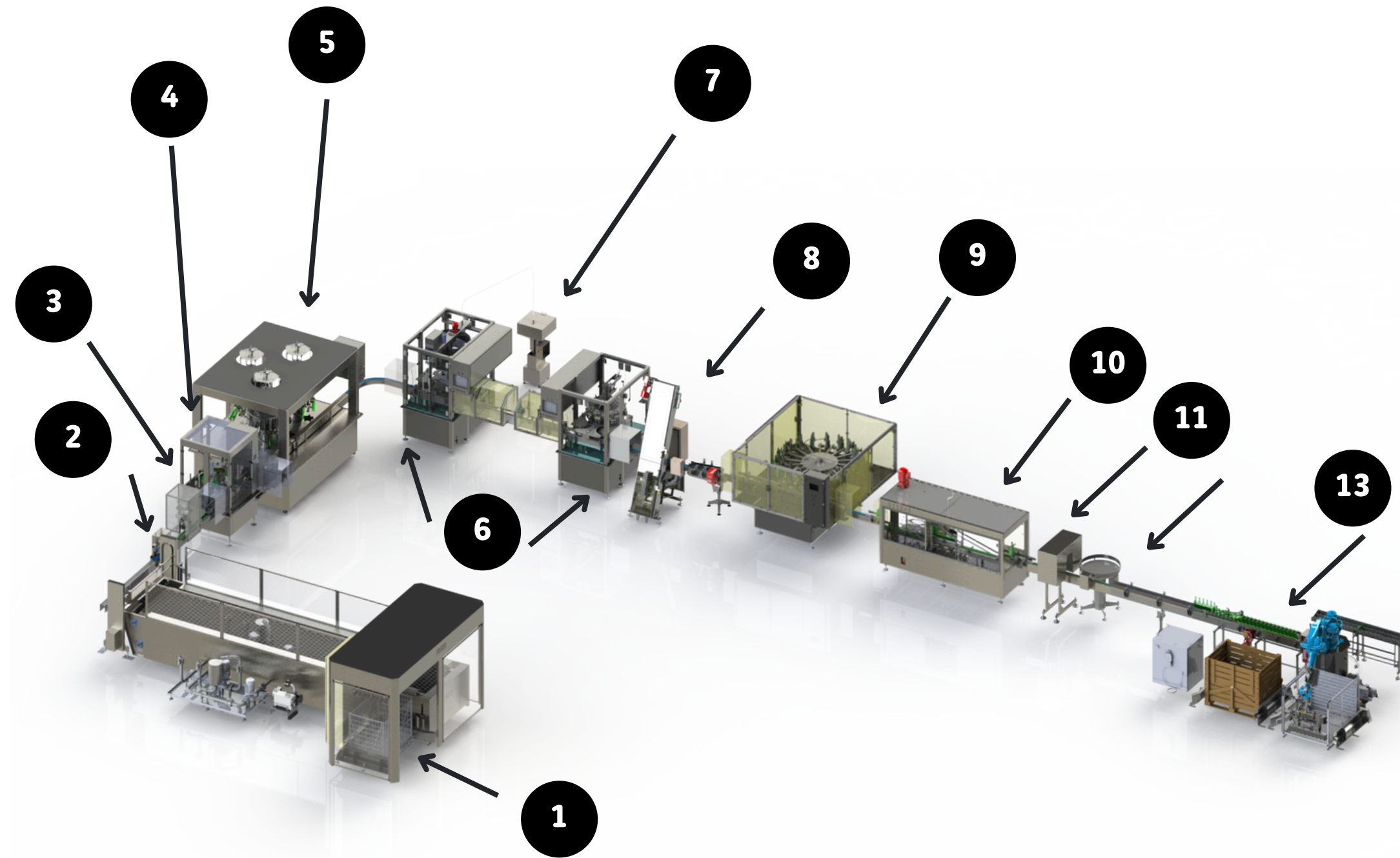

- 1 Neck freezer
- 2 Neck rinsing tunnel
- 3 Beating machine
- 4 Automatic rotary disgorging machine
- 5 Automatic dosing machine
- 6 Rotary corking wiring machine
- 7 Cork distributor and orientator
- 8 Semi-automatic case destocking of wirehoods
- 9 Mixing machine
- 10 Washing drying machine
- 11 Control vision
- 12 Ejection table
- 13 Automatic emboxing



# DISGORGING

## SPARKLING WINE

### AUTOMATIC DISGORGING LINE 4000 b/h

1

**Neck freezer  
BGL 3000**



2

**Neck rinsing tunnel  
RC Inox**



3

**Beating machine  
MAF 1**

Working height. . 1000 mm +/- 100 mm  
Dimensions (L x D x H). . 420 x 600 x 1850 mm  
Pressure. . 6 bars  
Air consumption : 5 m<sup>3</sup>/h to 6 bars  
Production rate : 4000 b/h  
Weight : 50 kg



4

**Automatic disgorging rotating machine**



5

**Automatic dosing machine**



# DISGORGING

## SPARKLING WINE

### AUTOMATIC DISGORGING LINE 4000 b/h

6

#### Rotary corking wiring machine

Supply voltage : 400 volts tri

Power : 6 Kw

Working height : 1050 mm +/- 50 mm

Dimensions (L x D x H) : 4000 x 1425 x 2200 mm

Air consumption : 5 m<sup>3</sup>/h to 6 bars

Production rate : 4800 b/h

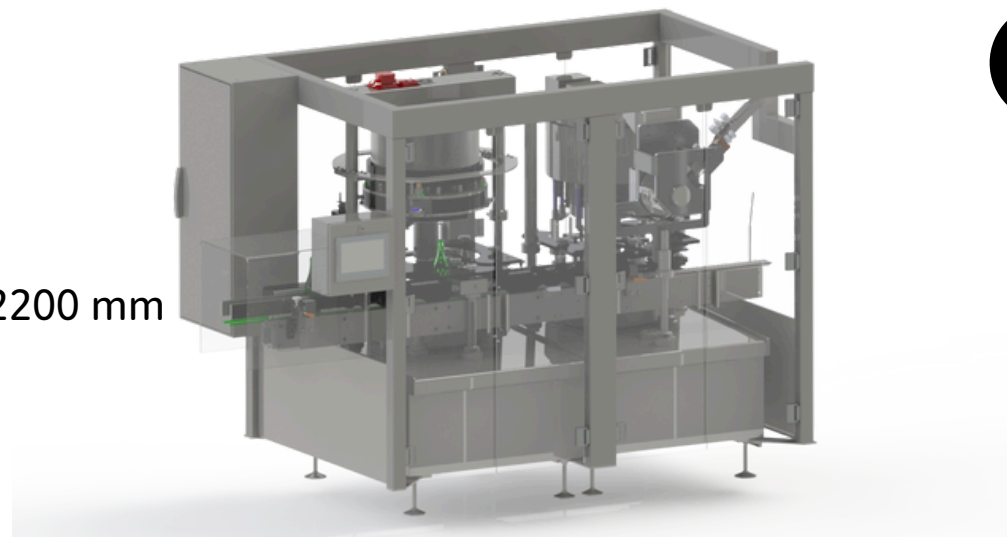

7

#### Cork distributor and orientator DOB 4000

Supply voltage : 400 volts tri

Power : 0,50 Kw

Dimensions (L x D x H) : 750 x 800 x 1810 mm

Air consumption : 10 m<sup>3</sup>/h to 6 bars

Production rate : 4000 to 10 000 b/h



8

#### Semi automatic case destocking of wirehoods Mini-decaisseur

Supply voltage : 400 volts tri

Power : 1,00 Kw

Dimensions (L x D x H) : 1000 x 1350 x 2750 mm

Air consumption : 2 m<sup>3</sup>/h to 6 bars

Production rate : 6000 b/h

Weight : 300 kg



8

#### Automatic case destocking of wirehoods

Supply voltage : 400 volts tri

Power : 5,00 Kw

Working height : 670 mm

Dimensions (L x D x H) : 4435 x 1050 x 2960 mm

Air consumption : 6 m<sup>3</sup>/h to 6 bars

Production rate : 12 000 b/h



# DISGORGING

## SPARKLING WINE

### AUTOMATIC DISGORGING LINE 4000 b/h

9

#### Mixing machine

Supply voltage : 400 volts tri

Power : 1,5 Kw

Working height : 950 mm +/- 50 mm

Dimensions (L x D x H) : 2500 x 2650 x 1765 mm

Production rate: 6 000 b/h

Weight. . 650 kg

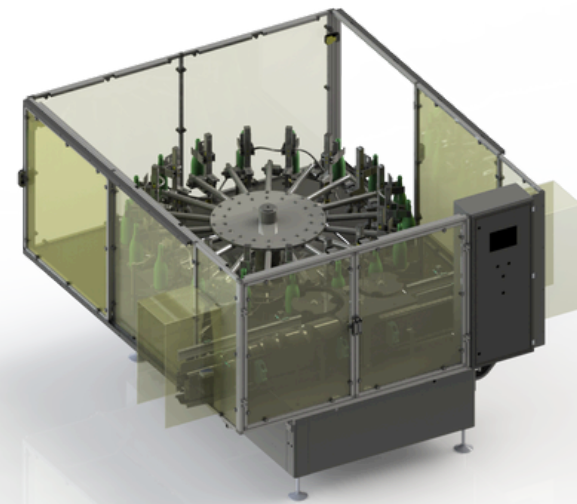

10

#### Washing drying machine

Power : 18,00 Kw

Working height : 1000 mm

Dimensions (L x D x H) : 2840 x 1105 x 2200 mm

Water consumption. : 100 l/h

Production rate : 3000 b/h

Weight : 580 kg



11

#### Control vision



12

#### Reception table TMD 800-1000



13

#### Automatic emboxing

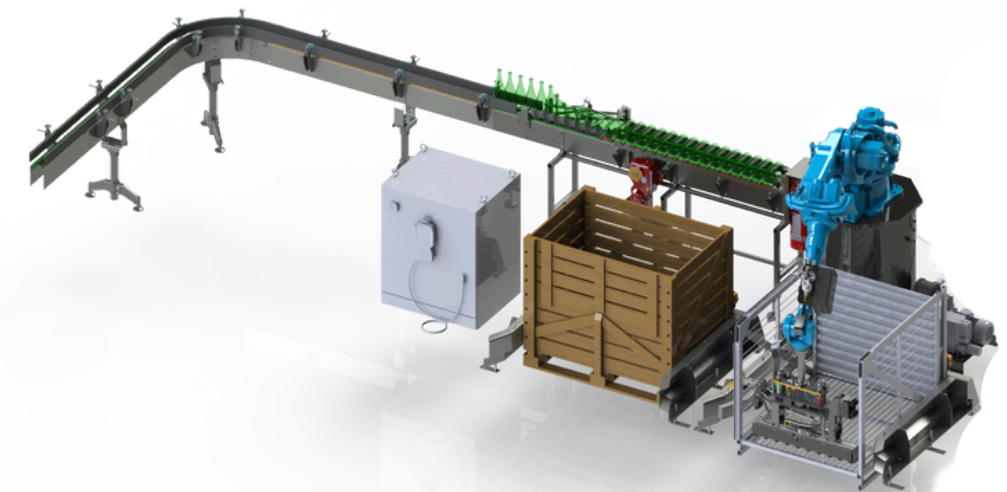

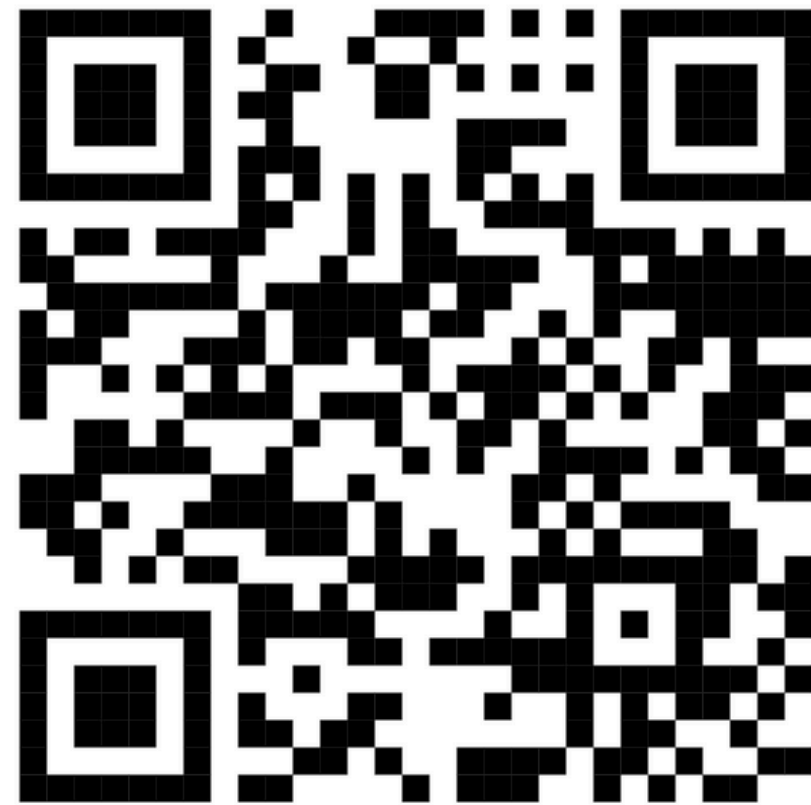

**Scan to discover our  
Youtube channel**